

# Hot Water Recirculation Control (HW)

# Hot Water Loop Temperature Sensor Installation

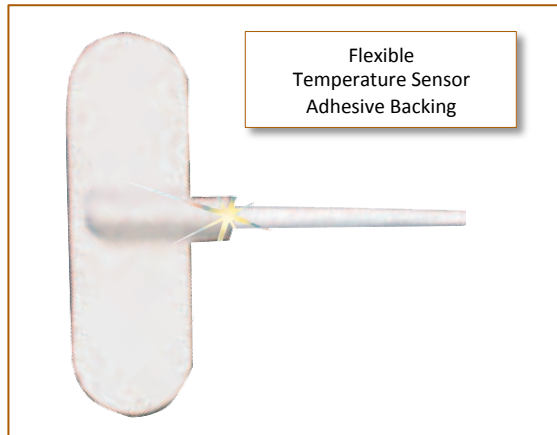
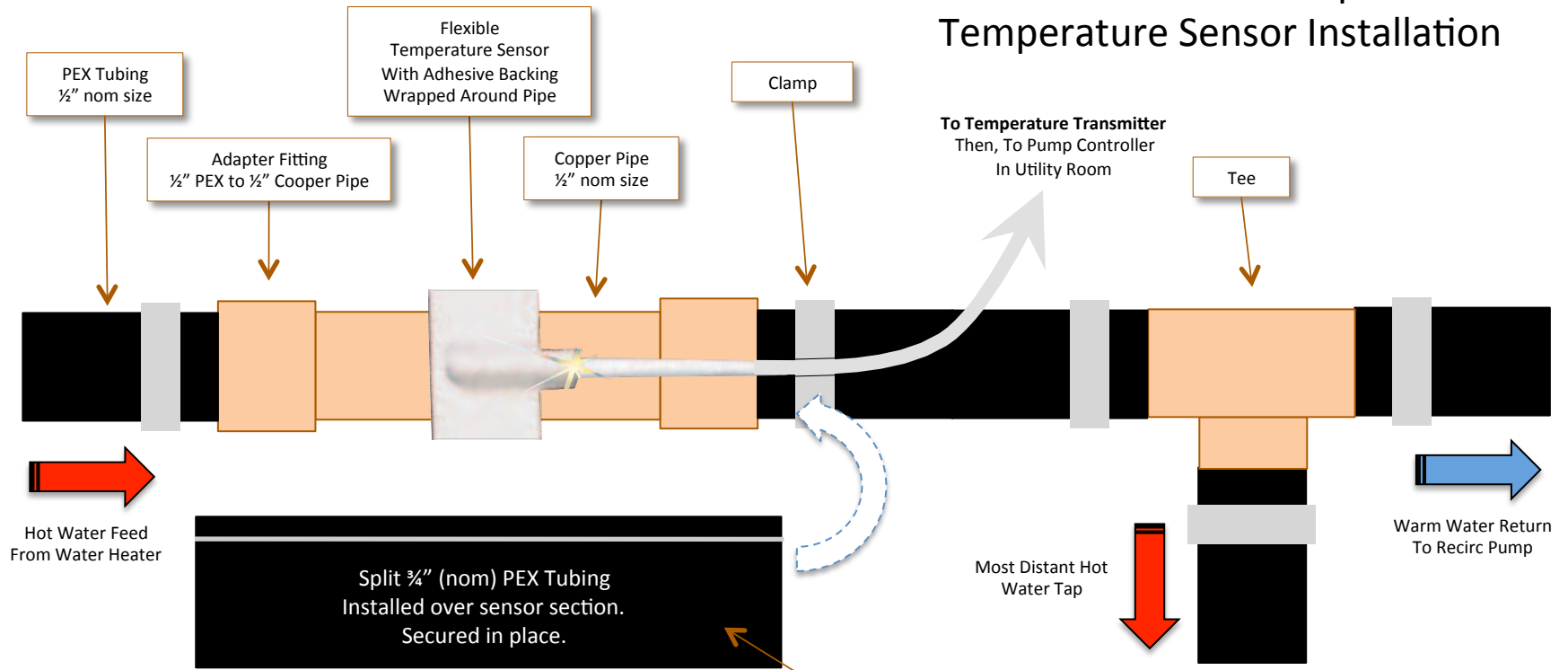
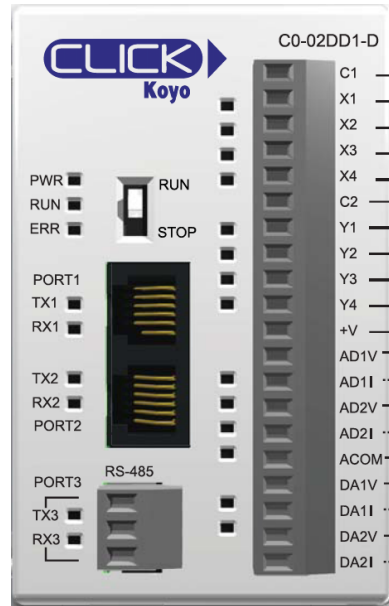

Reduces thermal conductivity of  
copper sensor section to that of PEX  
distribution tubing.

**Modules**

**CPU:** C0-02DD1-D; 4 DC in, 4 DC Sink Out  
2 Analog In, 2 Analog Out

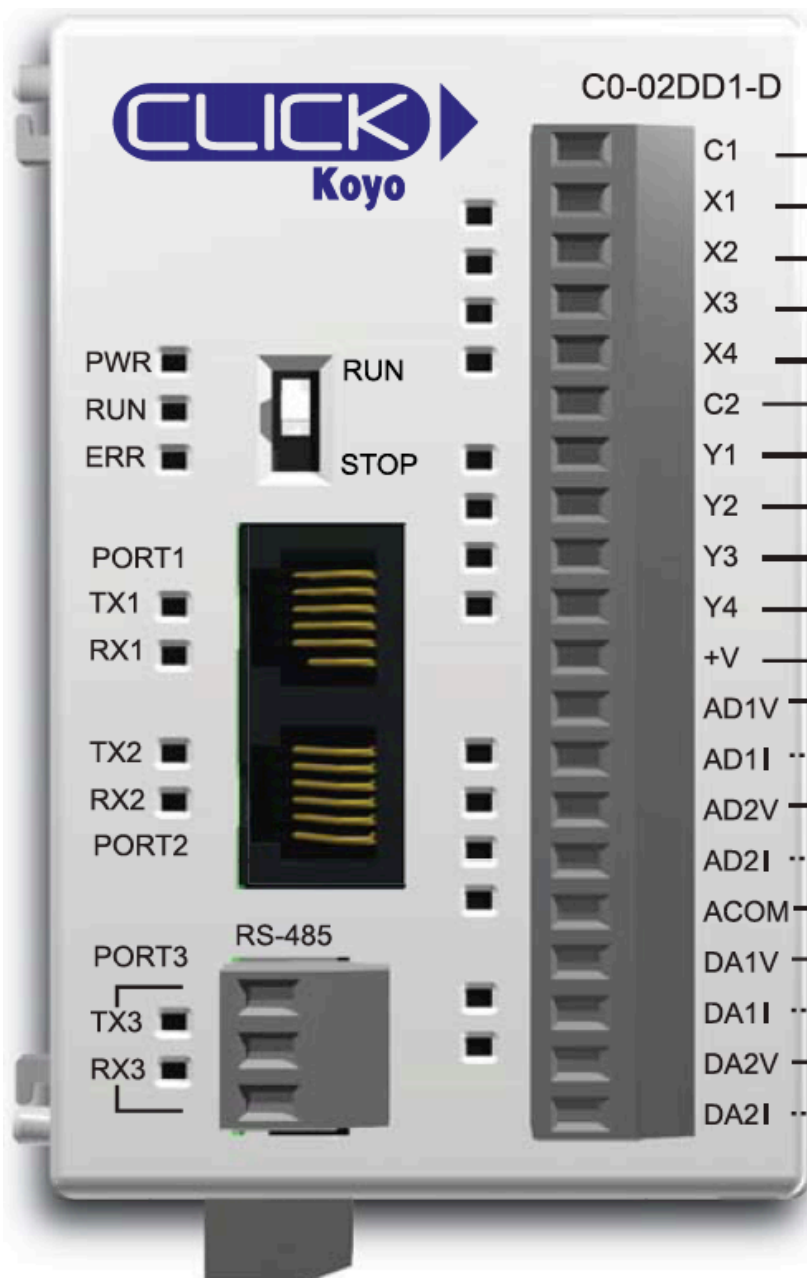

### Wiring Diagram

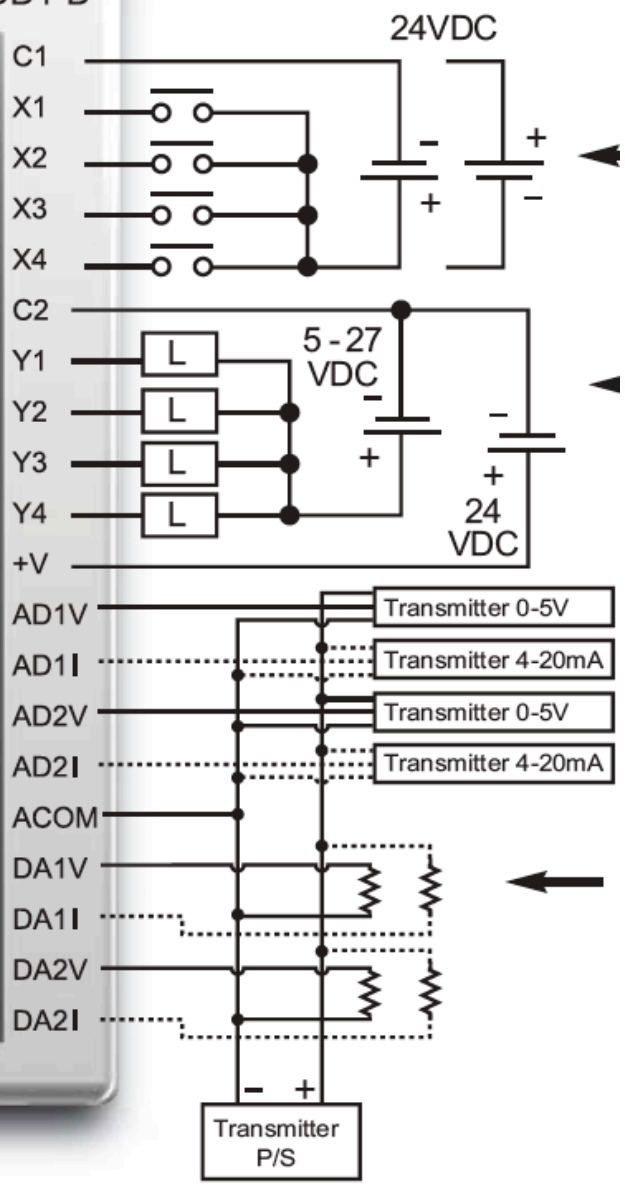

Temperature Transmitter: Omega TX94A-2  
 RTD: Omega SA2C-RTD-3-100-B-80

4 mA = 0 deg F  
 20 mA = 200 deg F

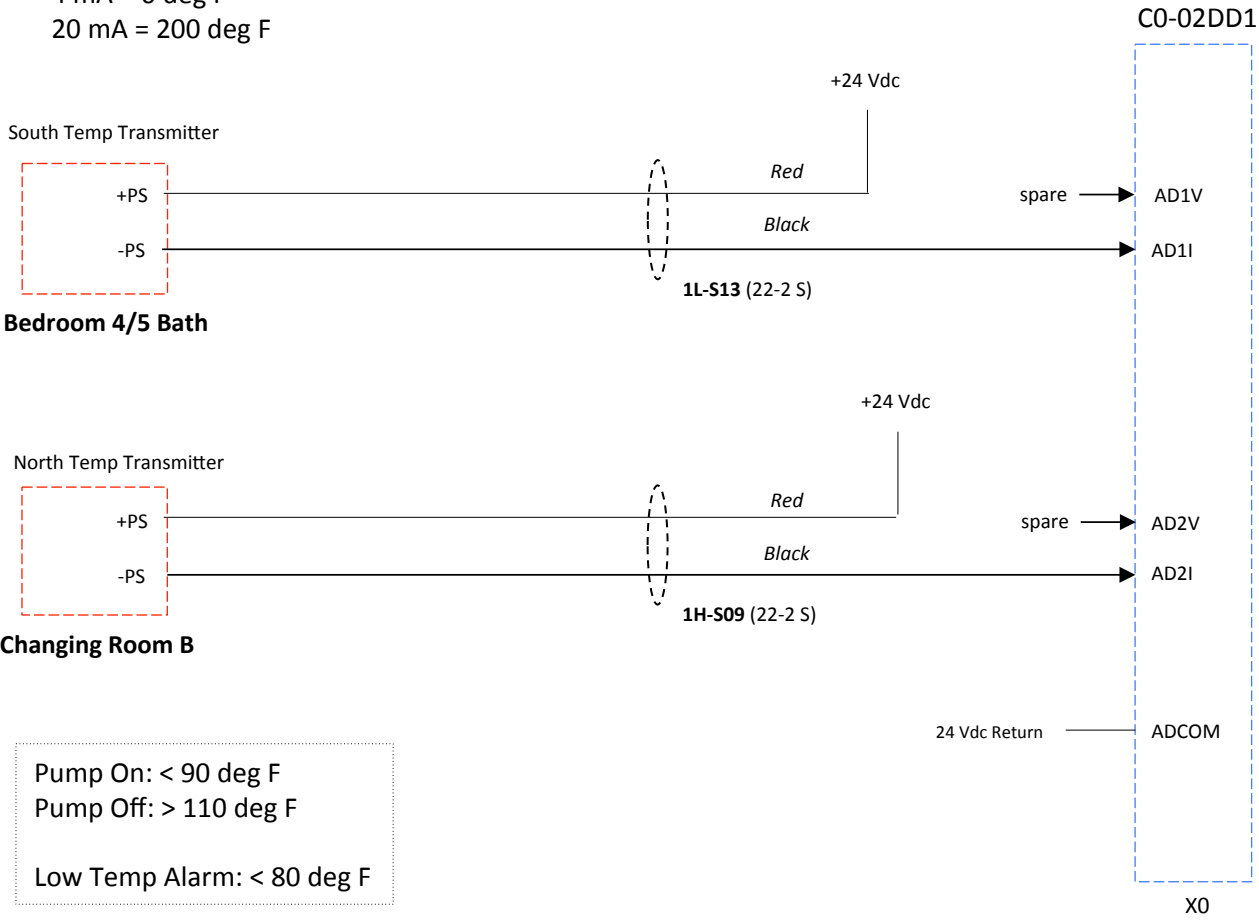

Pump On: < 90 deg F  
 Pump Off: > 110 deg F  
 Low Temp Alarm: < 80 deg F

